



Evo Affinity 30G Outdoor Gas Cooktop



Certification: ANSI Z83.11b-2009/CSA 1.8b-2009
Part #: Commercial models: 10-0054-NG, 10-0054-LP
Residential models: 10-0055-LP, 10-0055-NG
Doc: OM-C&R-30G v4 02/2016 Report# 141-S-03-5
Copyright ©2017

Cleaning Instructions



evoamerica.com

INSTALLATION INSTRUCTIONS

Affinity 30G

THIS MANUAL MUST BE RETAINED FOR FUTURE REFERENCE. READ, UNDERSTAND, AND FOLLOW THE INSTRUCTIONS AND WARNINGS CONTAINED IN THIS MANUAL.

DANGER

POTENTIALLY HAZARDOUS SITUATION WHICH, IF NOT AVOIDED, COULD RESULT IN DEATH



WARNING

POTENTIALLY HAZARDOUS SITUATION WHICH, IF NOT AVOIDED, COULD RESULT IN DEATH OR SERIOUS INJURY



CAUTION

POTENTIALLY HAZARDOUS SITUATION WHICH, IF NOT AVOIDED, MAY RESULT IN MINOR OR MODERATE INJURY.



CAUTION

Helpful tips and technique instructions are shown.



Notes

To Installer or Person Uncrating Grill:

Leave these instructions with purchaser.

To Purchaser:

Keep these instructions for future reference.

Complete Now For Future Reference

Model # _____ Serial # _____

Date Purchased _____ Location Purchased _____

Date Installed _____ Location Installed _____

Warnings

FOR YOUR SAFETY

1. Do not store or use gasoline or other flammable vapors and liquids in the vicinity of this or any other appliance.
2. An LP Tank not connected for use shall not be stored in the vicinity of this or any other appliance.

FOR YOUR SAFETY

If You Smell Gas:

1. Shut off gas to appliance.
2. Extinguish any open flame.
3. Remove grill cooking surface.
4. If odor continues, immediately call your gas supplier or your fire department.
5. Evacuate all personnel from the area.

WARNING

It is the responsibility of the assembler/owner to assemble, install and maintain gas grill. Do not let children operate or play near your grill. Failure to follow these instructions could result in serious personal injury and / or property damage.

WARNING

This symbol identifies the most important safety messaging in this manual. When you see this symbol, be alert to the possibility of serious bodily injury if the instructions are not followed. Be sure to read and carefully follow all of the messages.

WARNING

Improper installation, adjustment, alteration, service or maintenance can cause property damage, injury or death. Read the installation, operating and maintenance instructions thoroughly before installing or servicing this equipment.

WARNING

Grill is for outdoor use only. Grill should be operated in a well-ventilated space. Never operate near flammable liquids or vapors. Do not install or use grill within 36" of combustible materials from back and sides of grill. Grill shall not be located under unprotected overhead made of combustible construction. Do not obstruct the flow of combustion and ventilation air, including ventilation of cylinder enclosures, if applicable.

READ FIRST IMPORTANT PRODUCT AND SAFETY INFORMATION

WARNING INSTALLATION OF THIS UNIT MUST BE DONE BY A QUALIFIED PLUMBER AND ELECTRICIAN. INCORRECT INSTALLATION CAN CAUSE INJURY TO PERSONNEL AND/OR DAMAGE TO EQUIPMENT. THIS UNIT MUST CONFORM WITH ALL LOCAL CODES, OR IN THE ABSENCE OF LOCAL CODES, WITH THE *NATIONAL FUEL GAS CODE, ANSI Z223.1/NFPA 54*, OR THE *NATURAL GAS AND PROPANE INSTALLATION CODE, CSA B149.1*, AS APPLICABLE INCLUDING:



1. THIS UNIT AND ITS INDIVIDUAL SHUTOFF VALVE MUST BE DISCONNECTED FROM THE GAS SUPPLY PIPING SYSTEM DURING ANY PRESSURE TESTING OF THE SYSTEM AT TEST PRESSURES IN EXCESS OF 1/2 PST (3.5 kPa).
2. THIS UNIT MUST BE ISOLATED FROM THE GAS SUPPLY PIPING SYSTEM BY CLOSING ITS INDIVIDUAL MANUAL SHUTOFF VALVE DURING ANY PRESSURE TESTING OF THE GAS SUPPLY PIPING SYSTEM AT TEST PRESSURES EQUAL TO OF LESS THAN 1/2 PSI (3.5 kPa).

WARNING DO NOT INSTALL THIS UNIT TO COMBUSTIBLE SURFACES, AND DO NOT USE COMBUSTIBLE MATERIALS IN THE CONSTRUCTION OF ANY COUNTER, STAND, OR OTHER DEVICE.



WARNING IMMEDIATELY AFTER CONNECTING GAS SUPPLY LINE AND BEFORE FIRST IGNITION, CHECK ALL GAS CONNECTIONS WITH SOAPY WATER TO TEST FOR LEAKS.



WARNING KEEP WATER AND ALL COOKING SPILL OVERS AWAY FROM FRONT CONTROL PANEL AND ALL OPEN SERVICE AREAS. NEVER HOSE UNIT, OR SPRAY UNIT WITH CLEANING SOLUTIONS.



CAUTION CAREFULLY FOLLOW ALL INSTALLATION INSTRUCTIONS AND CONSTRUCT ALL COUNTER SPACE, STANDS, OR OTHER SURFACES TO THE RECOMMENDED INSTALLATION SPECIFICATIONS AS OUTLINED IN THIS MANUAL.



CAUTION THIS UNIT IS HEAVY AND SHOULD BE INSTALLED BY TWO PEOPLE. USE NECESSARY BLOCKING FOR LOCATING COOK SURFACE AND CONNECTING TEMPERATURE SENSORS TO THE UNDERSIDE OF COOK SURFACE.



CAUTION ALWAYS KEEP ANY AND ALL FLAMMABLE LIQUIDS AND COMBUSTIBLE MATERIALS AWAY FROM UNIT. DO NOT STORE TOWELS OR UTENSILS, OR ANY OTHER ITEMS ON UNIT'S DRIP PAN.



CAUTION DO NOT CLEAN THE COOK SURFACE WITH GRILL BRICKS OR CLEANING SOLUTIONS. USE ONLY GRILL SCREENS AND GRILL PADS AND FOLLOW THE PRESCRIBED METHOD OF CLEANING AS OUTLINED IN THIS MANUAL.



NOTICE THE SERIAL NUMBER AND MODEL INFORMATION LABEL PLATE IS LOCATED UNDERNEATH THE CONTROL PANEL.



NOTICE INSTALLATION OF ANY VENT HOODS OR FIRE EXTINGUISHER SYSTEMS MUST CONFORM TO THE NATIONAL, STATE, AND LOCAL BUILDING AND ALL APPLICABLE UNIFORM CONSTRUCTION CODES.



NOTICE DURING THE FIRST FEW HOURS OF OPERATION IT IS NORMAL FOR OILS USED IN THE MANUFACTURING PROCESS TO BURN OFF AND GIVE AN ODOR OR PETROLEUM SMOKE.



FOR OUTDOOR USE ONLY

This appliance shall only be used in an above ground open-air situation with natural ventilation, without stagnant areas, where gas leakage and products of combustion are rapidly dispersed by wind and natural convection.

Any enclosure in which the appliance is used shall comply with one of the following:

- An enclosure with walls on all sides, but at least one permanent opening at ground level and no overhead cover. See Figure 1.
- Within a partial enclosure that includes an overhead cover and no more than two walls. See Figure 2 & 3.
- Within a partial enclosure that includes an overhead cover and more than two, the following shall apply:
 - At least 25% of the total wall area is completely open; and
 - At least 30% of the remaining wall area is open and unrestricted. See Figure 4 & 5.
- In the case of balconies, at least 20% of the total side, back and front areas shall be and remain open and unrestricted.

The following diagrams provide a diagrammatic representation of outdoor areas. Rectangular areas have been used in these figures - the same principles apply to any other shaped area.

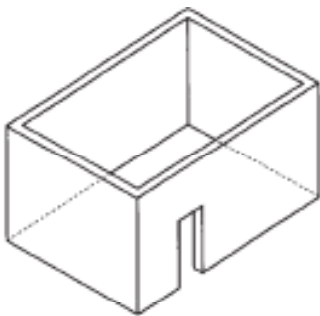

Figure 1 - Enclosure with walls on all sides but no overhead cover.

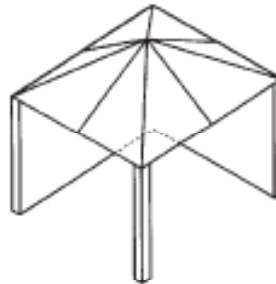

Figure 2 - Partial Enclosure with overhead cover and no more than two walls.

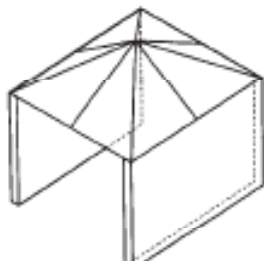
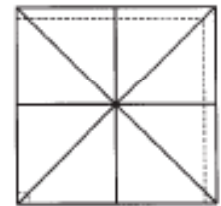

Figure 3 - Partial Enclosure with overhead cover and no more than two walls.

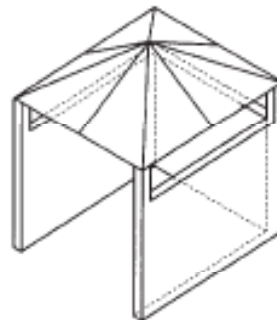
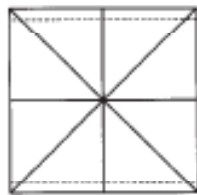
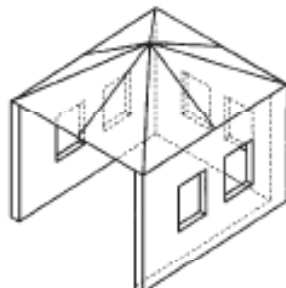
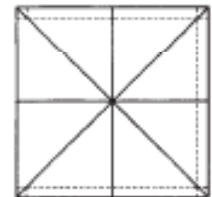

Figure 4 - Open side at least 25% of total wall area. 30% or more in total of the remaining wall area is open and unrestricted



This appliance is not intended to be installed in or on boats, and is not intended to be installed in or on recreational vehicles.

EVO RESIDENTIAL LIMITED WARRANTY TERMS

Evo, Incorporated warrants to the original residential consumer-purchaser that the Evo grill shall be free from rust-through on all metal surfaces and shall be free from defects in materials and workmanship under normal and reasonable use from the original date of purchase. Evo promises to replace, at its determination, any product or component that is defective and covered under this warranty for as long as you, the registered original consumer-purchaser, owns the grill. This is your sole and exclusive remedy. This warranty is for the benefit of the original consumer-purchaser and is non-transferable. This warranty is subject to the limitations, exclusions and other provisions listed below.

Limitations Involving Materials and Components:

Warranty does not apply to normal wear and tear, which are expected over the course of ownership. The materials and components listed below are covered according to the following schedule from the original date of purchase:

- **One Year** – electrical and electronic components [including, but not limited to, electronic displays, overlay and membrane switches, temperature sensors (RTD and K-Value Thermal Couple), hot surface igniters, computers, transformers, heater elements, relays, igniters, ignition controllers, wiring, switches, encoders, outlets and plugs]
- **One Year** – gas components [including, but not limited to, gas regulator, gas hoses, manifold assemblies]
- **One Year** – accessories and repair parts

The Warranty Registration Card (or online warranty registration form available at www.evoamerica.com/content/residential-warranty-registration) must be completed and returned/submitted to Evo, Incorporated within 30 days from the date of purchase. The original purchase invoice or payment record must be retained and produced upon request if claims are made under this warranty. To receive a replacement Warranty Registration Card, write or call the address listed at the bottom of this page. Warranties are void if the original serial numbers have been removed, altered, or cannot be readily determined.

THIS WARRANTY APPLIES ONLY TO PRODUCTS PURCHASED AND LOCATED WITHIN THE UNITED STATES OR CANADA.

WHAT IS NOT COVERED BY THIS WARRANTY

1. Conditions and damages resulting from any of the following:
 - a. Improper or inadequate installation, delivery, use, storage or maintenance
 - b. Any repair not authorized in writing by Evo, Inc., any modifications, misapplications, or unreasonable use
 - c. Improper setting of any control
 - d. Harsh environmental conditions, including, but not limited to, continual seawater spray, high pressure water, and direct contact with corrosive chemicals and materials
 - e. Excessive or inadequate electrical, or gas supply
 - f. Accidents, natural disasters, acts of God
 - g. Conditions covered by the purchaser's insurance
 - h. Cleaning supplies and filters
2. Products purchased or utilized for commercial use without the express authorization of Evo, Incorporated for such use
3. Labor not pre-authorized by Evo, Incorporated, and labor not performed by an authorized Evo service agency or representative
4. Pre-authorized warranty labor performed outside of normal business hours, and at overtime and premium rates
5. The cost of service or a service call to:
 - a. Identify or correct installation errors
 - b. Transport the product or component for service to/from the manufacturer or service center
 - c. Instruct the user of the proper use of the product
6. The cost for any inconvenience, personal injury or property damage due to failure of the product, and cost of damage arising out of the transportation of the product which is covered under different terms with the carrier
7. Natural variations in color and finishes that are inherent to the material and unavoidable (and therefore not defects)

ALL IMPLIED WARRANTIES, INCLUDING THE IMPLIED WARRANTIES OF MERCHANTABILITY, SUITABILITY, QUALITY AND/OR FITNESS FOR A PARTICULAR PURPOSE, ARE LIMITED IN DURATION TO THE EXPRESS WARRANTY PERIODS SPECIFIED ABOVE FOR THE PARTS DESCRIBED THEREIN. EVO, INCORPORATED MAKES NO OTHER WARRANTY AND WILL NOT BE LIABLE FOR ANY DIRECT OR INDIRECT, CONSEQUENTIAL OR INCIDENTAL DAMAGES. Some states do not allow limitations on how long an implied warranty lasts, so the above limitation may not apply to you. Neither Evo manufacturer representatives and dealers, nor the retail establishment selling this product has any authority to make any warranties or to promise remedies in addition to or inconsistent with those stated above. The maximum liability to Evo, Incorporated in any event, shall not exceed the purchase price of the product paid by the original consumer-purchaser. Some states do not allow the exclusion or limitation of incidental or consequential damages, so the above limitations or exclusions may not apply to you. This warranty gives you specific legal rights, and you may also have other rights which vary from state to state.

EVO COMMERCIAL LIMITED WARRANTY TERMS

Evo, Incorporated warrants to the original commercial foodservice purchaser that the Evo cooking, refrigeration and ventilation equipment shall be free from rust through on all metal surfaces and shall be free from defects in materials and workmanship under normal and reasonable use for One Year from the original date of purchase from Evo, Inc. This warranty is for the benefit of the original use purchaser and is non-transferable. Evo promises to replace, at its determination, any product or component that is defective during this initial one year period. Or as a resolution, Evo may at its option repurchase the product at its original purchase price. This is your sole and exclusive remedy. This warranty is subject to the limitations, exclusions and other provisions listed below.

Limitations Involving Materials and Components:

Warranty does not apply to normal wear and tear, which are expected over the course of ownership. The materials and components listed below are covered according to the following schedule from the original date of purchase from Evo:

- **One Year** – electrical and electronic components [including, but not limited to, electronic displays, overlay and membrane switches, temperature sensors (RTD and K-Value Thermal Couple), hot surface igniters, computers, transformers, heater elements, relays, igniters, ignition controllers, wiring, switches, encoders, outlets and plugs]
- **One Year** – gas components [including, but not limited to, gas regulator, gas hoses, manifold assemblies]
- **One Year** – accessories and repair parts
- **Ninety (90) Days** - refrigeration components [including, but not limited to, compressor, evaporator, pressure control units]

The Warranty Registration Card (or online warranty registration form available at www.evoamerica.com/content/commercial-warranty-registration) must be completed and returned/submitted to Evo, Incorporated within 30 days from the date of purchase. The original purchase invoice or payment record must be retained and produced upon request if claims are made under this warranty. To receive a replacement Warranty Registration Card, write or call the address listed at the bottom of this page. Warranties are void if the original serial numbers have been removed, altered, or cannot be readily determined.

THIS WARRANTY APPLIES ONLY TO PRODUCTS PURCHASED AND LOCATED WITHIN THE USA OR CANADA.

WHAT IS NOT COVERED BY THIS WARRANTY:

1. Conditions and damages resulting from any of the following:
 - a. Improper or inadequate installation, delivery, use, storage or maintenance
 - b. Any repair not authorized in writing by Evo, Inc., any modifications, misapplications, or unreasonable use
 - c. Improper setting of any control
 - d. Harsh environmental conditions, including, but not limited to, continual seawater spray, high pressure water, and direct contact with corrosive chemicals and materials
 - e. Excessive or inadequate electrical, gas, or refrigeration supply
 - f. Accidents, natural disasters, acts of God
 - g. Conditions covered by the purchaser's insurance
 - h. Cleaning supplies and filters
2. Labor not pre-authorized by Evo, Incorporated, and labor not performed by an authorized Evo service agency or representative
3. Pre-authorized warranty labor performed outside of normal business hours, and at overtime and premium rates
4. The cost of service or a service call to:
 - a. Identify or correct installation errors
 - b. Transport the product or component for service to/from the manufacturer or service center
 - c. Instruct the user of the proper use of the product
5. The cost for any inconvenience, personal injury or property damage due to failure of the product, and cost of damage arising out of the transportation of the product which is covered under different terms with the carrier
6. Natural variations in color and finishes that are inherent to the material and unavoidable (and therefore not defects)

ALL IMPLIED WARRANTIES, INCLUDING THE IMPLIED WARRANTIES OF MERCHANTABILITY, SUITABILITY, QUALITY AND/OR FITNESS FOR A PARTICULAR PURPOSE, ARE LIMITED IN DURATION TO THE EXPRESS WARRANTY PERIODS SPECIFIED ABOVE FOR THE PARTS DESCRIBED THEREIN. EVO, INCORPORATED MAKES NO OTHER WARRANTY AND WILL NOT BE LIABLE FOR ANY DIRECT OR INDIRECT, CONSEQUENTIAL OR INCIDENTAL DAMAGES. Some states do not allow limitations on how long an implied warranty lasts, so the above limitation may not apply to you. Neither Evo manufacturer representatives and dealers, nor the commercial establishment selling this product has any authority to make any warranties or to promise remedies in addition to or inconsistent with those stated above. The maximum liability to Evo, Incorporated in any event, shall not exceed the purchase price of the product paid by the original commercial-purchaser. Some states do not allow the exclusion or limitation of incidental or consequential damages, so the above limitations or exclusions may not apply to you. This warranty gives you specific legal rights, and you may also have other rights which vary from state to state.

INSTALLATION CHECKLIST

	PAGE #
<input type="checkbox"/> UNPACK COOKTOP COMPONENTS Follow unpacking instructions carefully	9
<input type="checkbox"/> PREPARE COUNTERTOP FOR INSTALLATION	10-14
<input type="checkbox"/> INSERT CHASSIS IN COUNTERTOP	15
<input type="checkbox"/> INSTALL DRIP PAN	16-17
<input type="checkbox"/> INSTALL DRIP PAN GASKET	17
<input type="checkbox"/> ASSEMBLING COOK SURFACE RETAINING FASTENERS	18
<input type="checkbox"/> INSTALL COOK SURFACE AND TIGHTEN FASTENERS	19-21
<input type="checkbox"/> CONNECT GAS & CHECK FOR LEAKS	22-26
<input type="checkbox"/> CHECK INSTALLATION & TEST EVO	27

UNPACKING COOKTOP COMPONENTS

Cook Surface: Lift and separate cook surface from unit and place next to installation area.



The cook surface is heavy. Use caution when lifting.

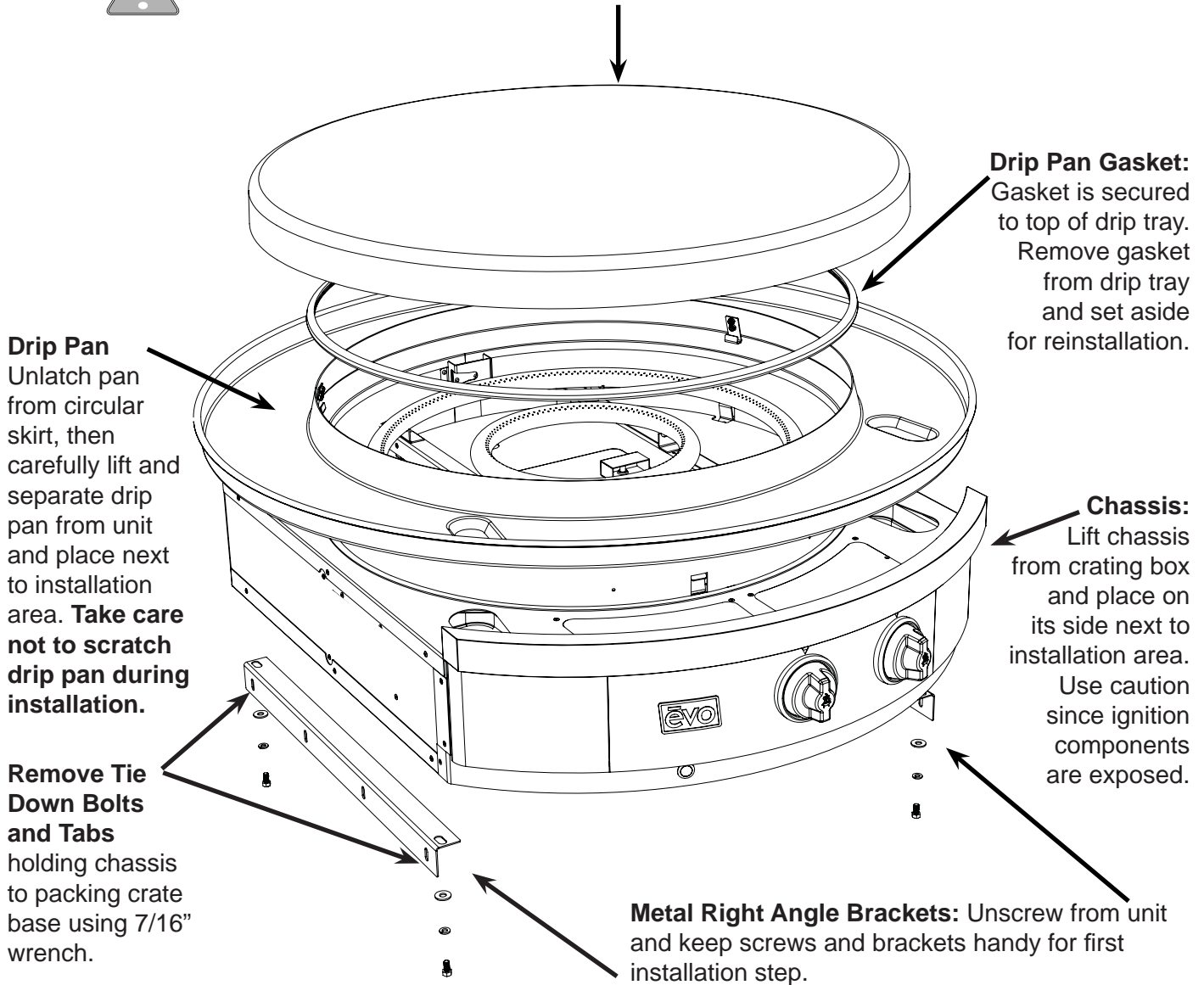

STEP 1: As you are unpacking the crate, make sure you locate all components before installation.



Ignition components are exposed during uncrating and installation. Use caution and do not alter factory set positions.

CLEARANCE DIMENSIONS

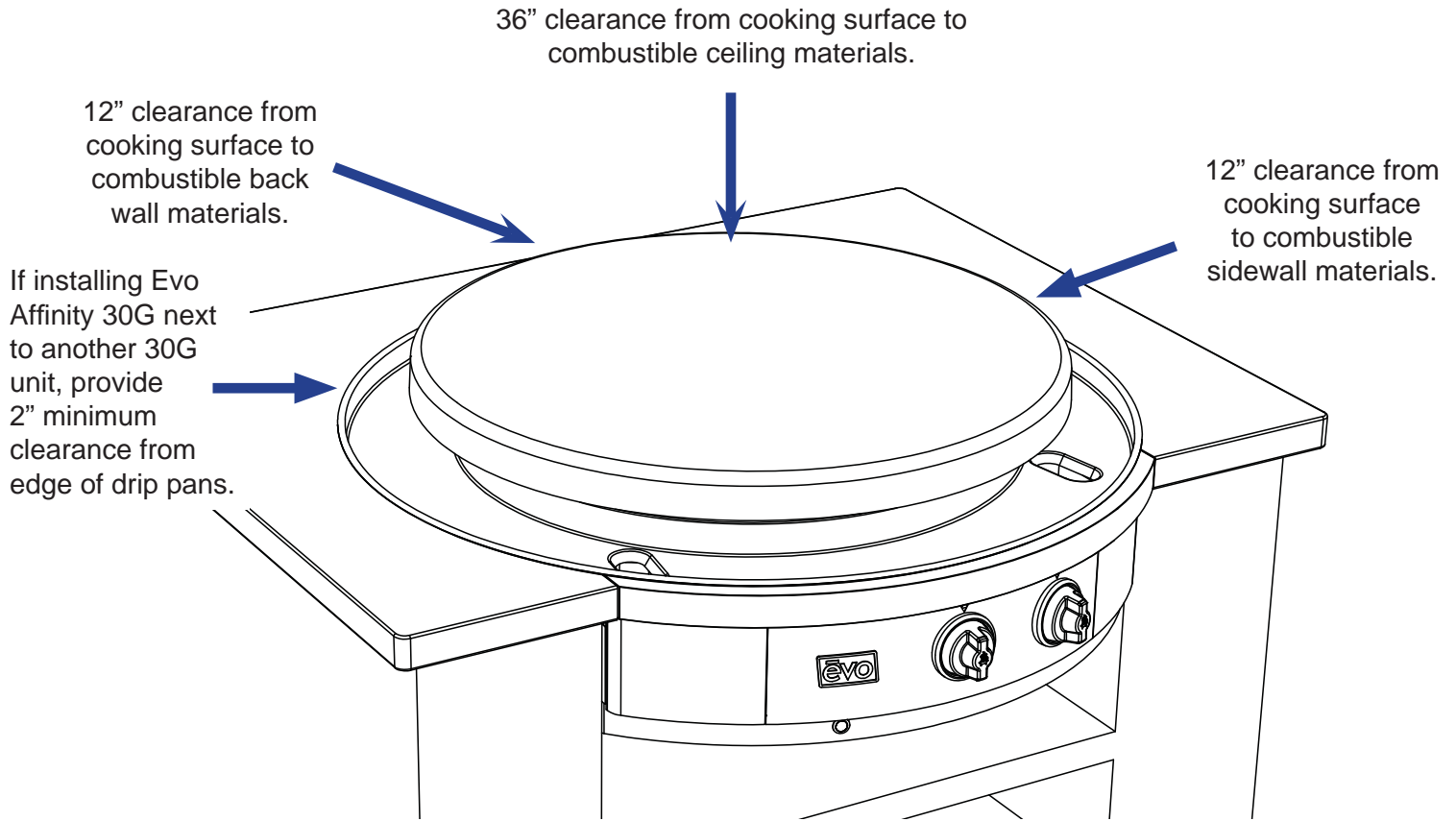

Minimum 3" clearance required under unit venting to 22 sq/in of combustible air.
 The minimum environmental temperature for safe use of the Evo Affinity 30G should not be below 30F degrees (-1 degree C).

CLEARANCE TO COMBUSTIBLE CONSTRUCTION FROM CHASSIS		
	Combustibles	Non-combustibles
Back	3/8"	0"
Sides	3/8"	0"
Bottom	3"	3"

CLEARANCE TO COMBUSTIBLE CONSTRUCTION FROM COOKING SURFACE	
Top	36"
Sides	12"
Back	12"

Read the instructions in the booklet carefully to install the Evo Affinity 30G Cooktop to a metal, stone or wood countertop surface. Cabinet layout and construction dimensions may vary.

COUNTERTOP INSTALLATION (1 of 4)

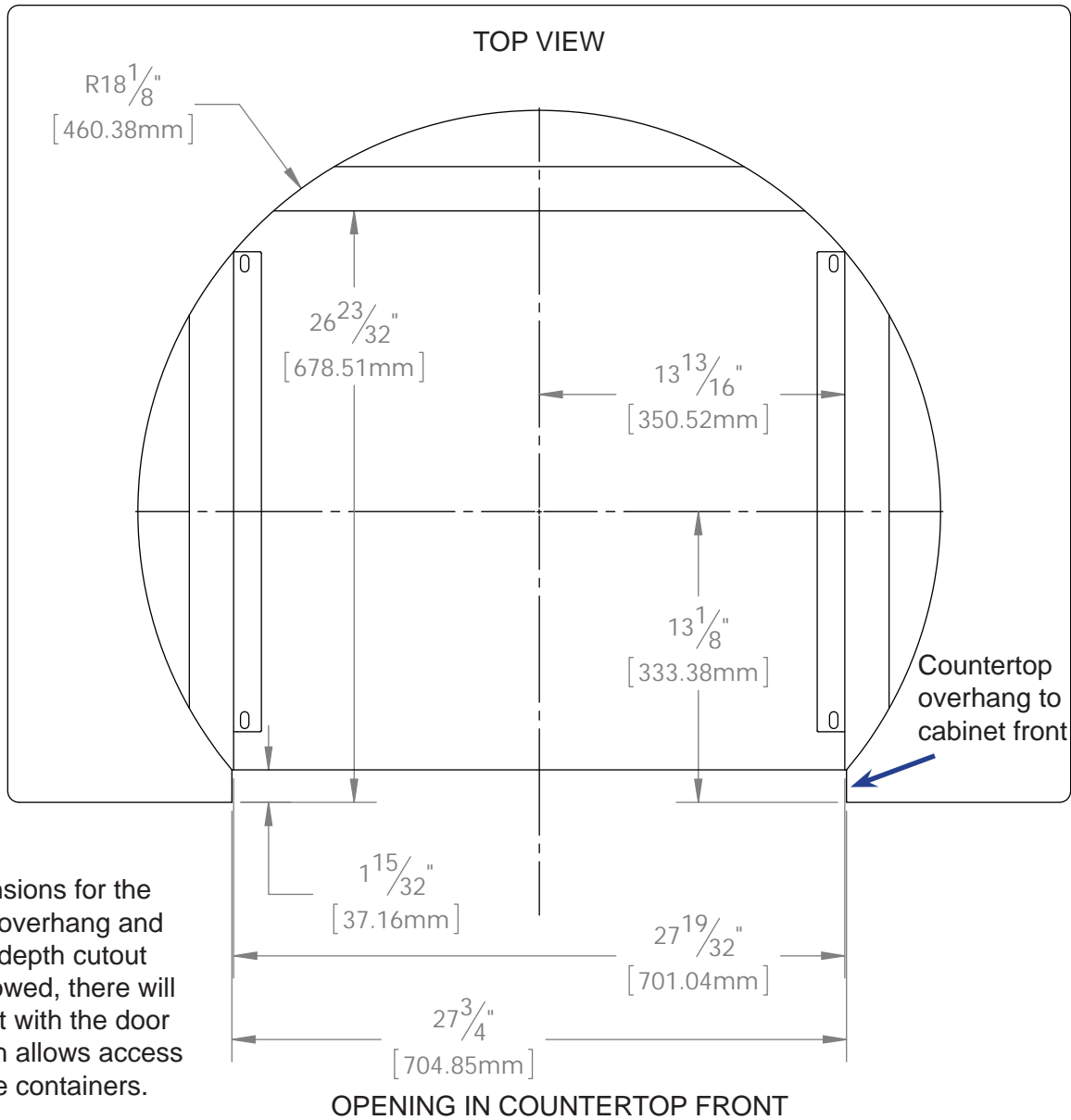

STEP 2: Mark the finished position of the Evo Affinity 30G drip pan on the countertop using the dimensions shown. The circular dimension of 36.25" is the diameter of the drip pan to the outside material thickness (e.g. to the inside of the rolled bead edge). The drip pan cutout must be made precisely to these dimensions (or at a maximum +1/16") so that the half-rolled top bead on the drip pan edge overhangs the cutout dimension by .25". (See following page for more details).

COUNTERTOP INSTALLATION (2 of 4)

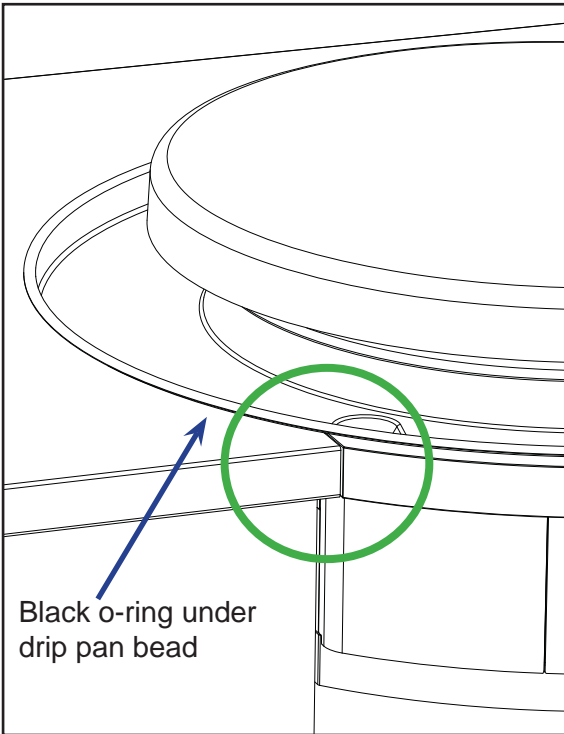

CORRECT ALIGNMENT OF DRIP PAN AND CHASSIS TO COUNTERTOP

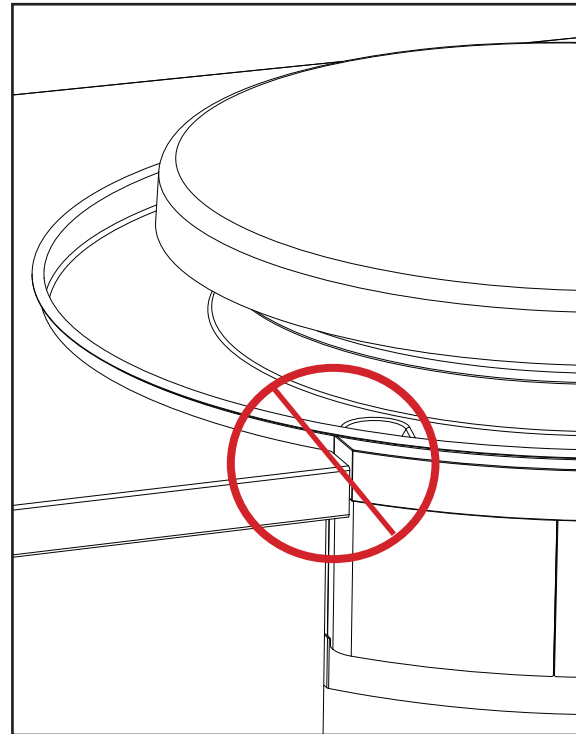

INCORRECT ALIGNMENT OF DRIP PAN AND CHASSIS TO COUNTERTOP

Possible reasons for incorrect alignment:

1. Top of cabinetry box is less than 3 cm from countertop
2. Chassis mounting brackets are too high.

STEP 2 continued: Make sure cabinetry box is 3cm (minimum) below countertop surface and mounting brackets are positioned correctly so drip pan and chassis are aligned to countertop(see diagrams above). A black o-ring is recessed in the top bead and designed to create a seal against the countertop.

Also ensure allowance for the countertop overhang as shown on the SIDE VIEW (**see next page**).

When you have confirmed the position is correct, cut the countertop and substrate.

COUNTERTOP INSTALLATION (3 of 4)

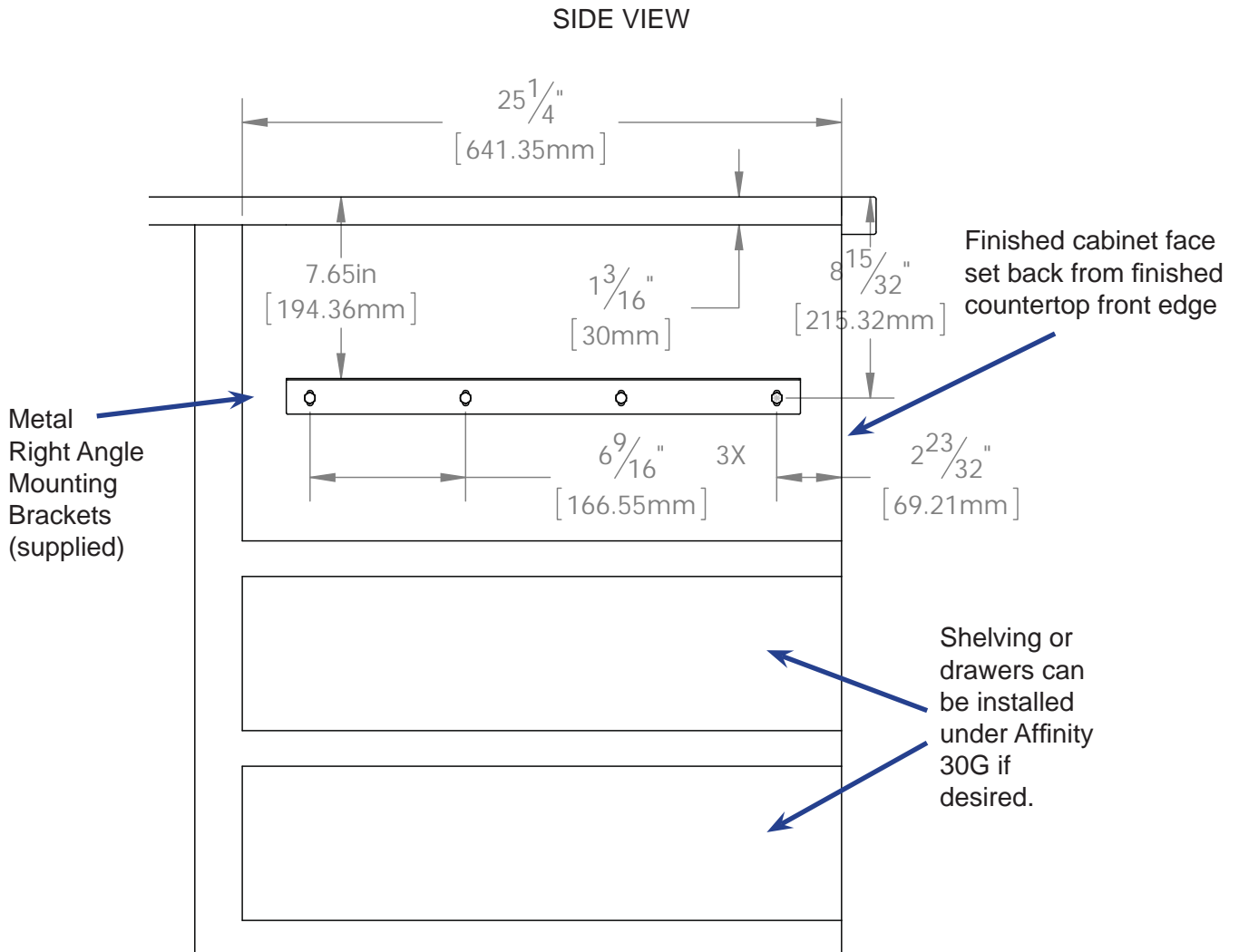

Example of $\frac{3}{8}$ " tile with substrate for a minimum 3 cm ($1\frac{1}{5}$ ") overall. Make sure you allow for the countertop overhang as shown.

COUNTERTOP INSTALLATION (4 of 4)

Example: Tiled countertop with substrate.
Finished countertop thickness should be
3 cm (1-1/5").

FRONT VIEW

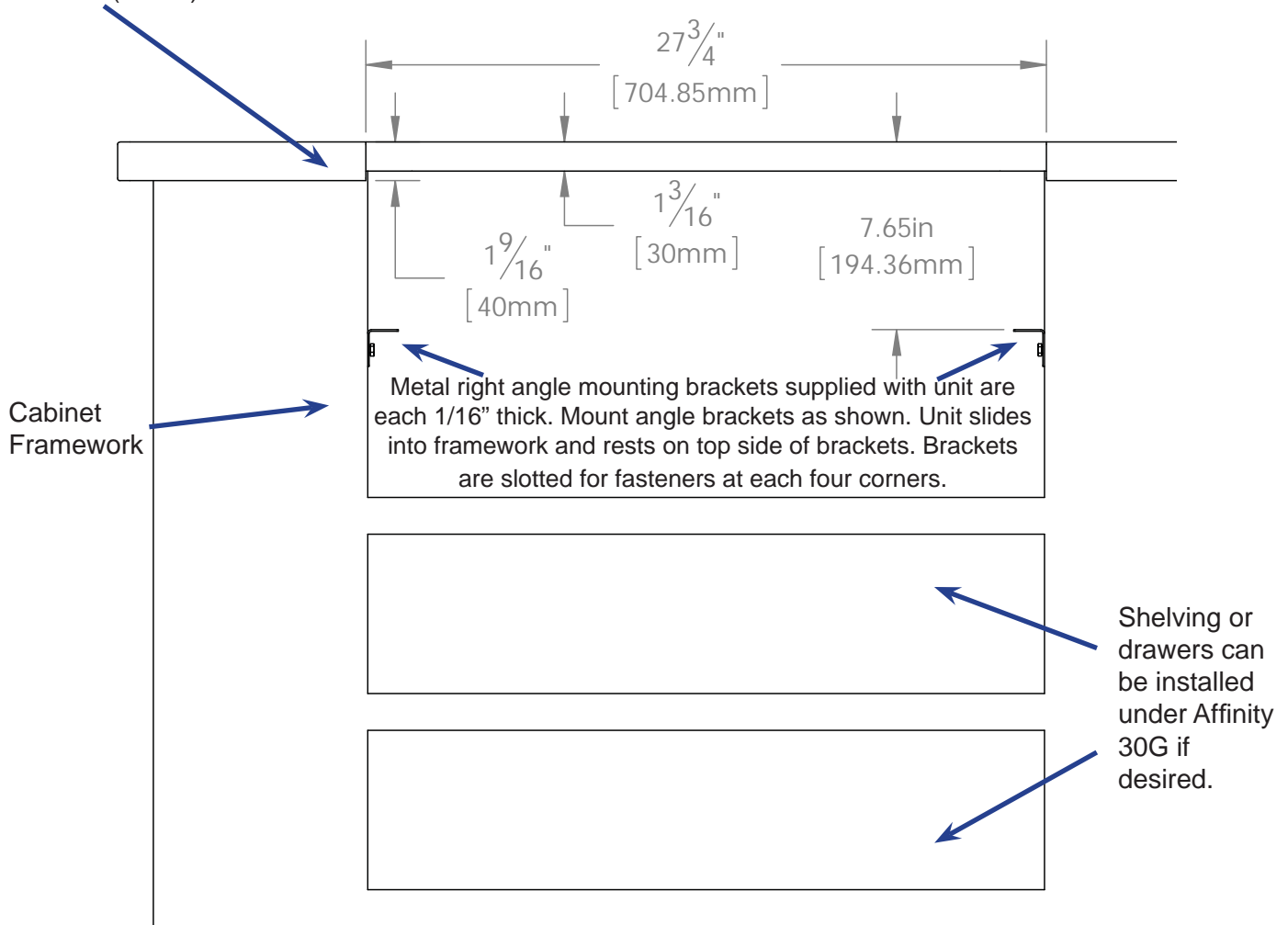

STEP 3: Construct a bay for the Evo unit with your chosen cabinet system. Position and fasten the supplied mounting brackets 7.65" below the finished countertop surface.

INSERT CHASSIS IN COUNTERTOP

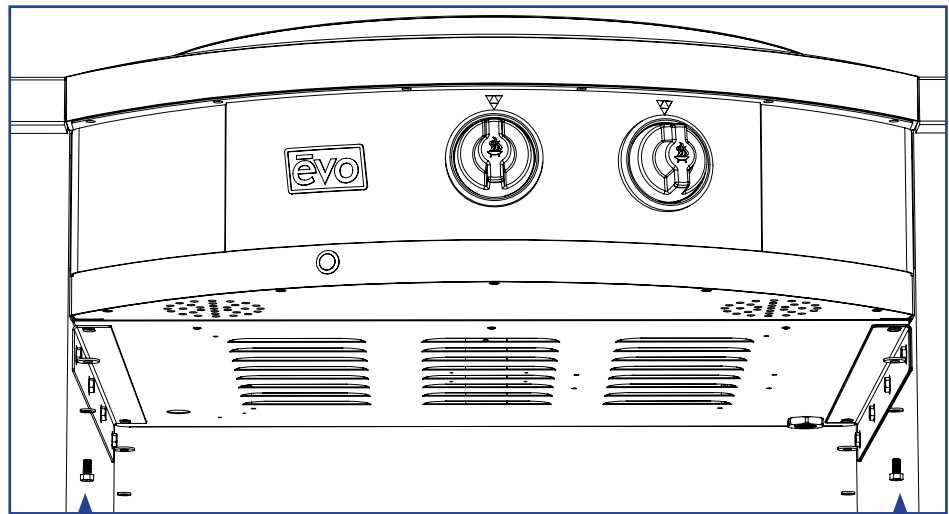
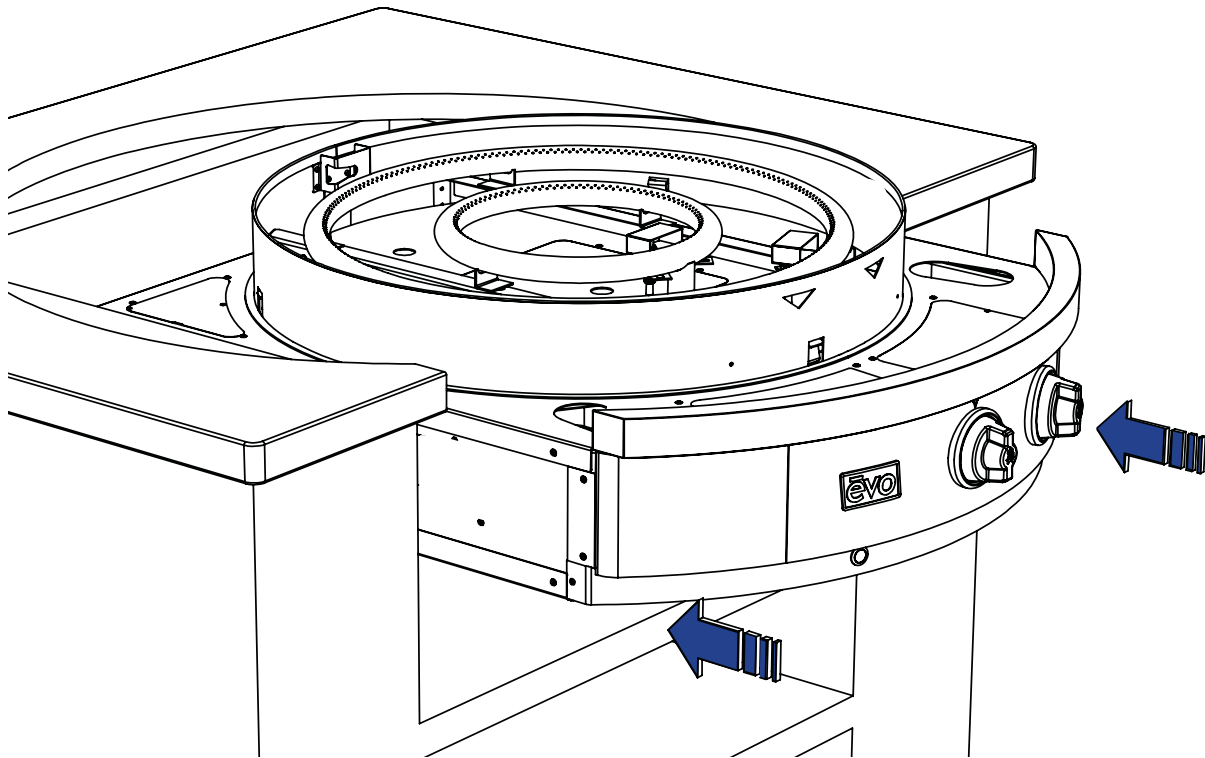

Use supplied 1/4" fasteners to bolt
chassis to angle brackets.

STEP 4: Slide the Affinity 30G chassis into the countertop so it rests on top of the installed brackets. Bolt unit to angle brackets using supplied 1/4" x 20 fasteners from underside.



Gas Installation must be done by a licensed professional in accordance with local guidelines once unit has been completely installed. Refer to pages 21-25 for further instructions.

DRIP PAN INSTALLATION

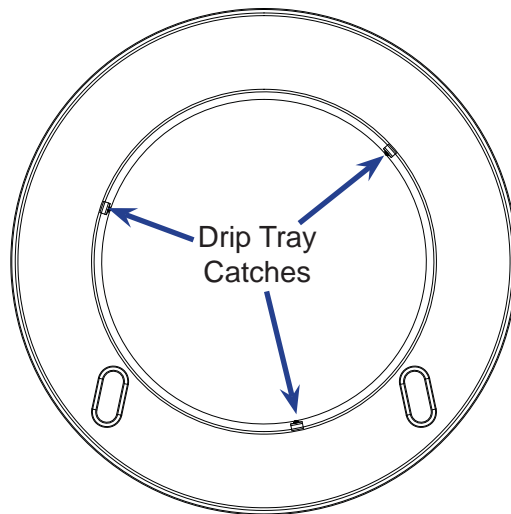
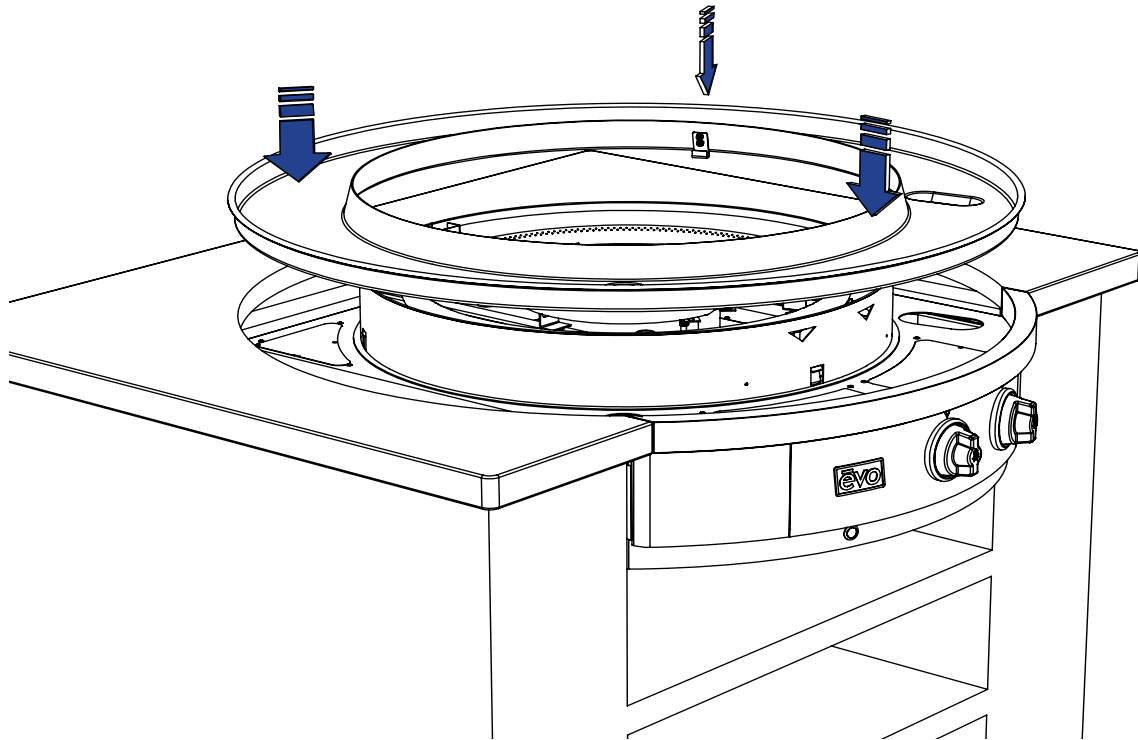

GRILL FRONT

STEP 5: Slide drip tray over chassis circular skirt positioning spillover slots to the corresponding slots of the top chassis deck. Notice the drip pan catches showing through the inside cutout locations of the circular chassis skirt. From the inside of the skirt, use each of the three latches to pull the drip pan down into the counter.

DRIP PAN AND GASKET INSTALLATION

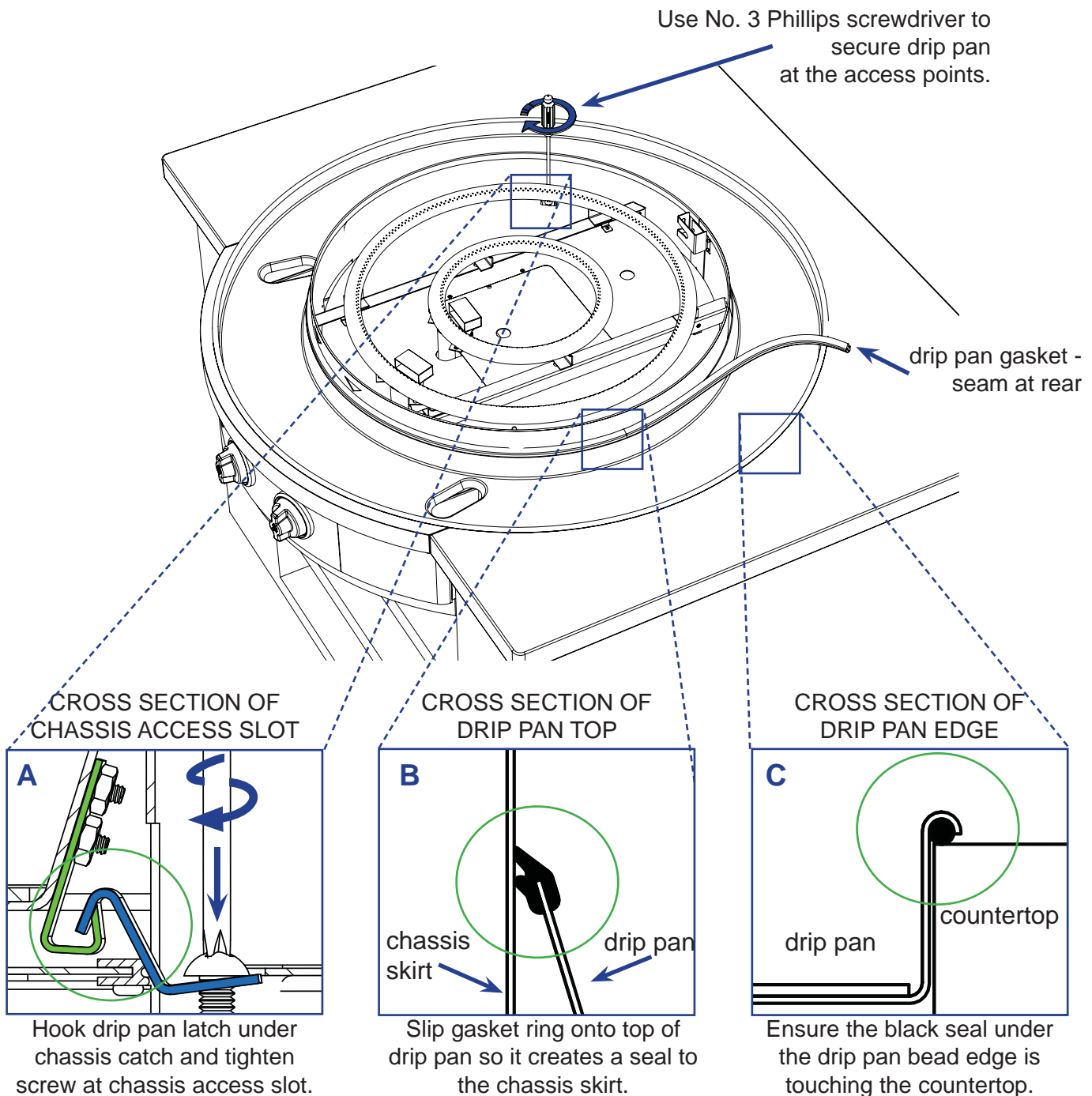

STEP 6: Secure drip pan to chassis using access slot (A). Rewrap drip pan gasket around top of drip tray and secure (B). Ensure seal under drip pan edge is touching countertop(C).

ASSEMBLING COOK SURFACE RETAINING FASTENERS



IT IS RECOMMENDED THE COOKING SURFACE BE PLACED ON A PROTECTED WORK SURFACE WITH THE FLANGE FACING UPWARD.

Using a 7/16" wrench, tighten the Rear Retaining Bullet to the cooking surface tab with two each 1/4" x 20 hex bolt and locking nut. Ensure the bolts are tightened securely.

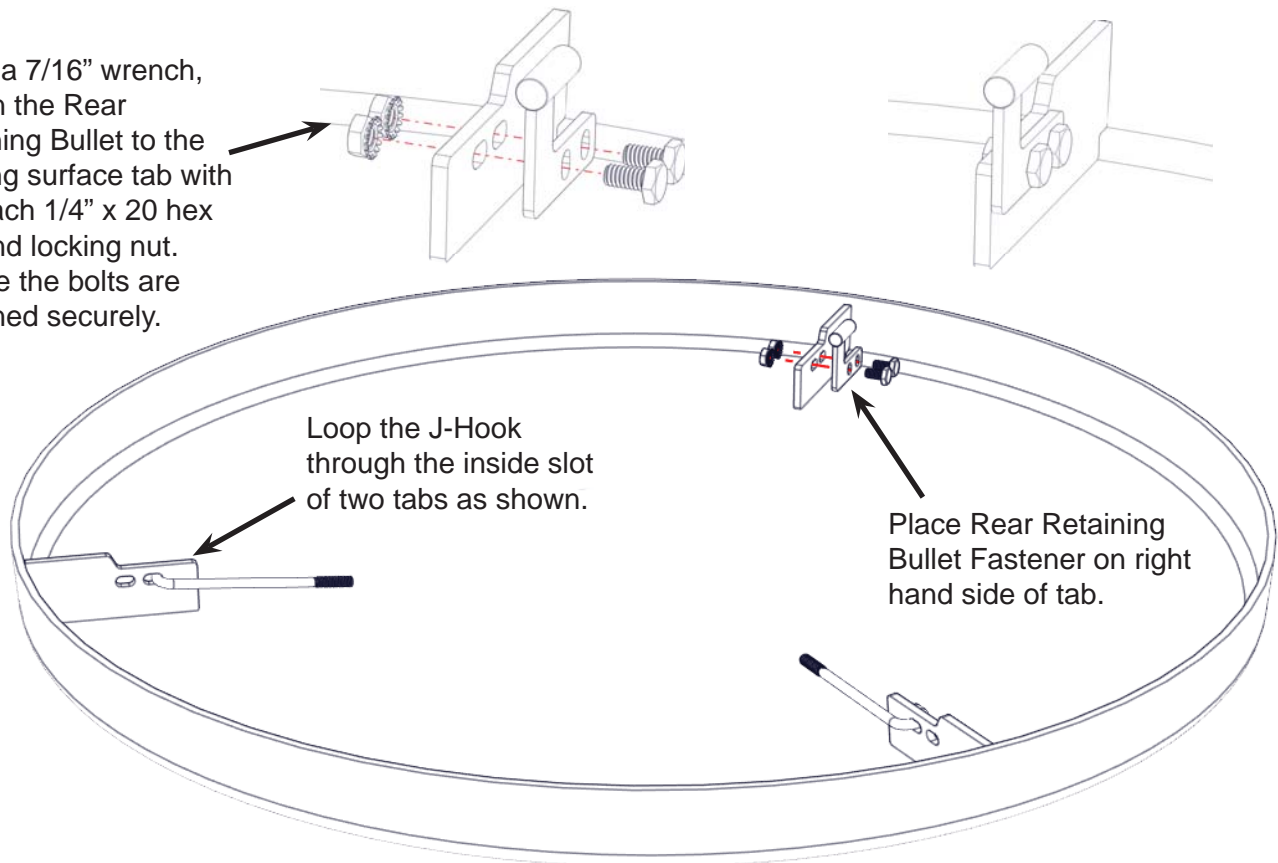

Loop the J-Hook through the inside slot of two tabs as shown.

Place Rear Retaining Bullet Fastener on right hand side of tab.

STEP 7: Locate Parts Box shipped with your Affinity 30G and the parts bag containing the Rear Retaining Bullet Fastener, two each 1/4" x 20 hex bolt and locking nut, and two each J-Hook. Follow the illustration show on this page, and using a 7/16" wrench tighten the Rear Retaining Bullet to a cook surface tab as shown (Ensure the Rear Retaining Bullet is placed on the right hand side of the tab). Next, loop the J-Hook through the inside slot of each remaining tab.

CONNECTING COOK SURFACE



IT IS RECOMMENDED THAT TWO PEOPLE LIFT AND POSITION THE COOKING SURFACE.

Place suitable protection on drip pan (towel or cardboard). Place cook surface vertically with Bullet Fastener facing downward.

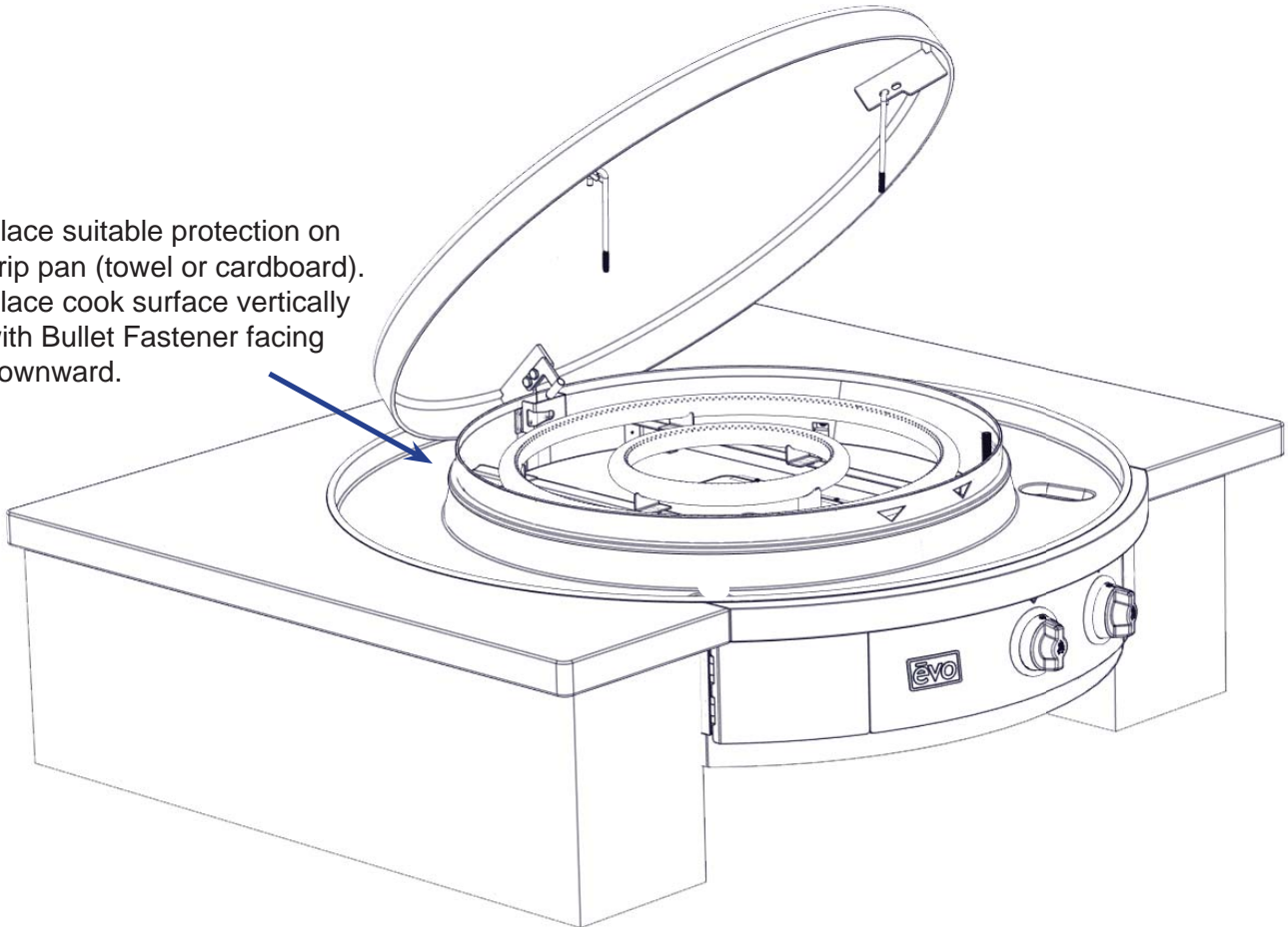

STEP 8: Position the cook surface at the rear of the burner chassis by placing the cook surface in the area of the drip pan, separated by a towel or cardboard to prevent damage to the drip pan.

INSTALLING COOK SURFACE

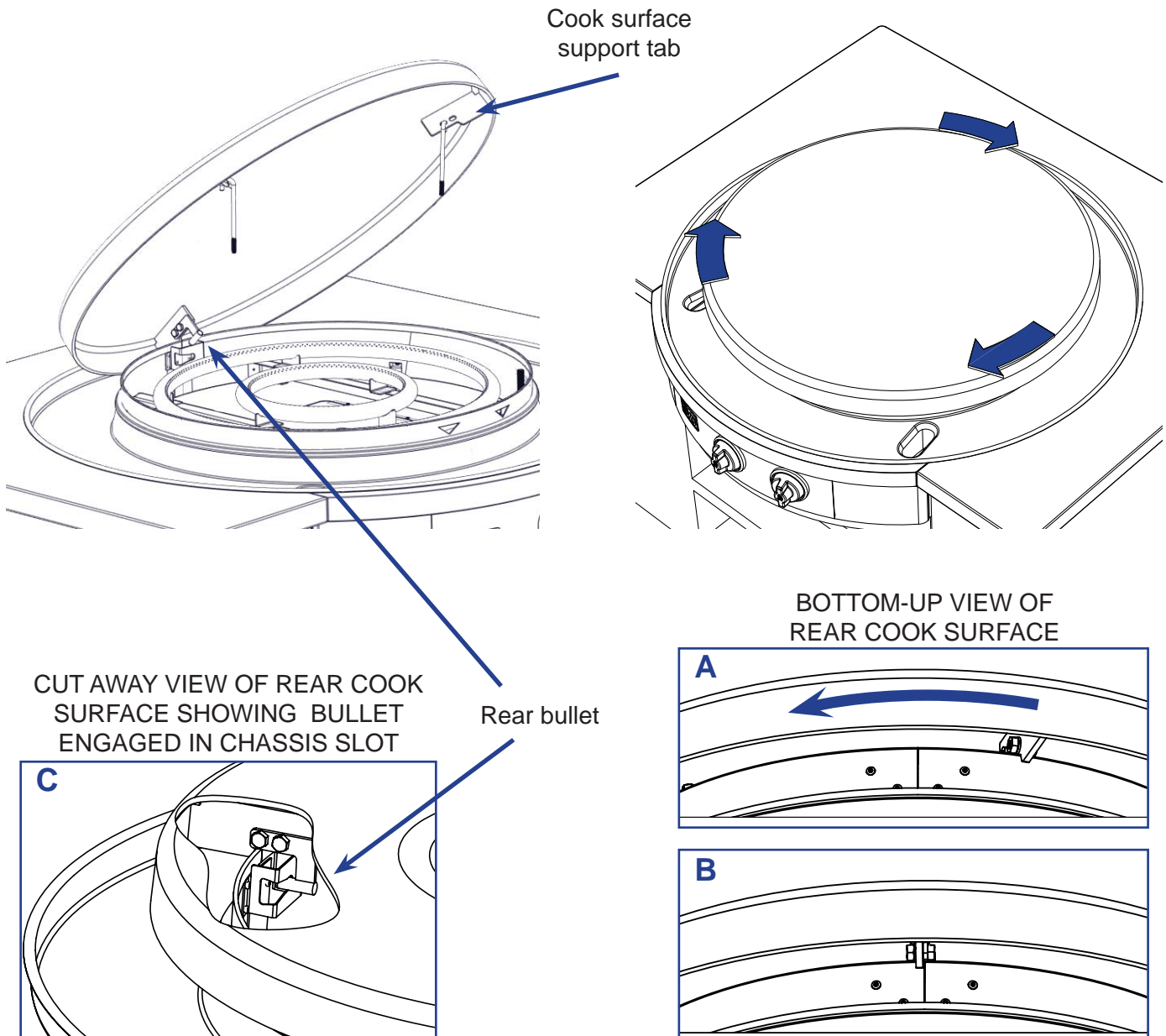

STEP 9: Place cook surface over circular skirt with the three support tabs (located under cook surface) resting on the chassis skirt top. Position the rear support tab of the cook surface to the right of the rear seam (rear view) of the chassis skirt **(A)**. Then rotate the cook surface clockwise until the support tab is in line with the seam **(B)** and the rear bullet secures in the chassis slot **(C)**.

INSTALLING COOK SURFACE

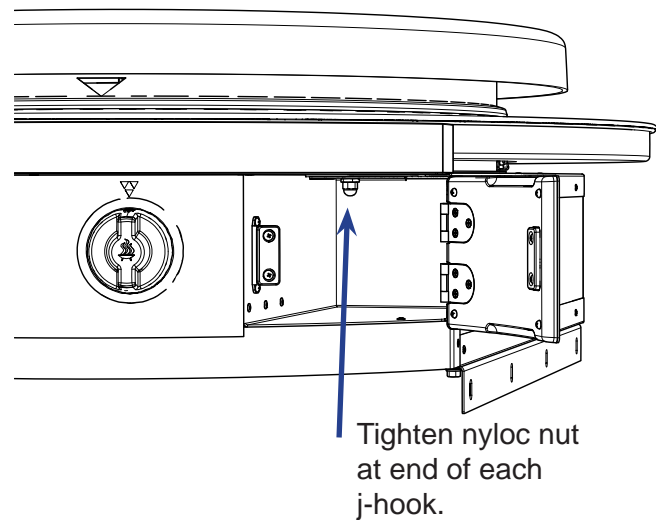
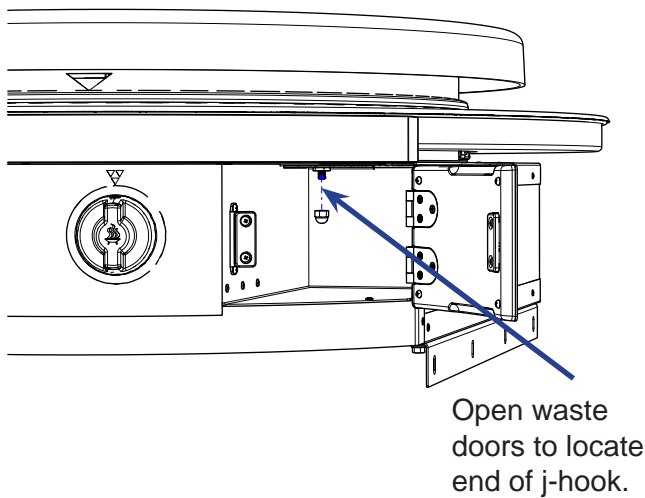
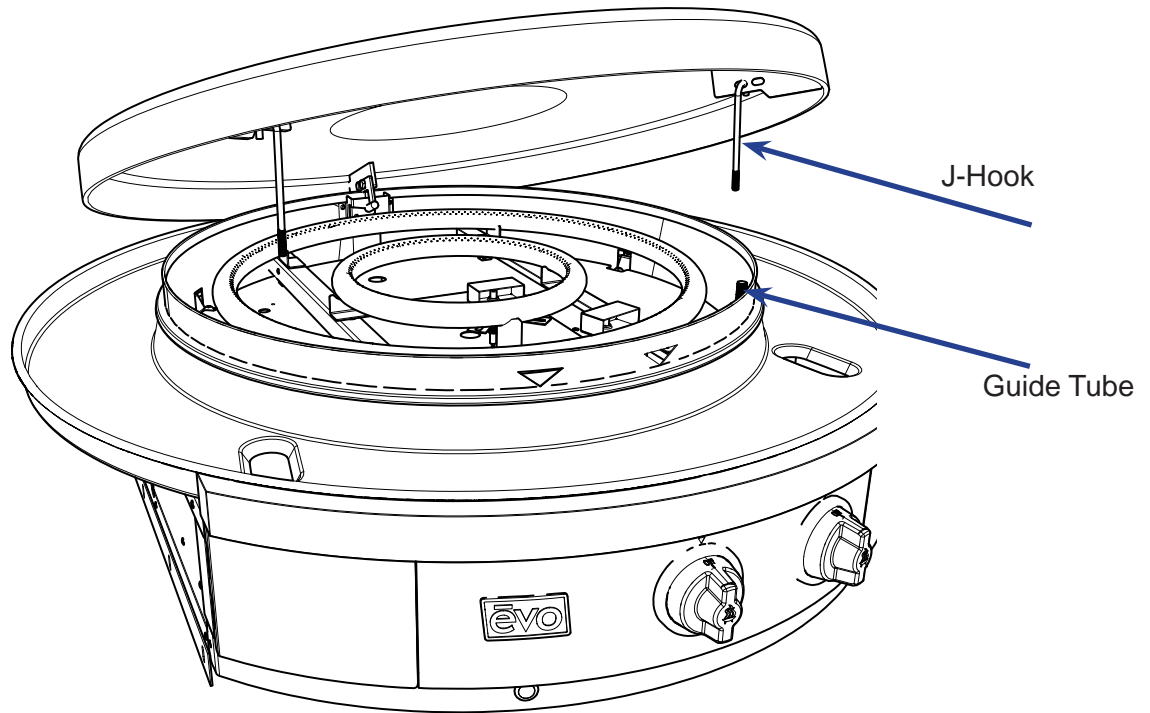

STEP 10: Locate two (2) j-hooks attached to underside of cooktop, cut zip ties and remove nyloc nut.

One at a time, slide j-hooks through guide tubes. Slowly place cooktop down. Open both waste doors and tighten nyloc nut on end of j-hook located at inside rear of each waste door.

CONNECTING GAS



FOR YOUR PROTECTION, WE RECOMMEND A QUALIFIED GAS TECHNICIAN INSTALL THIS COOKTOP. THIS PERSON SHOULD BE FAMILIAR WITH GAS SERVICE INSTALLATIONS AND ALL LOCAL CODES. PROPER CONNECTIONS ARE ESSENTIAL FOR EFFICIENT OPERATION AND SAFETY.

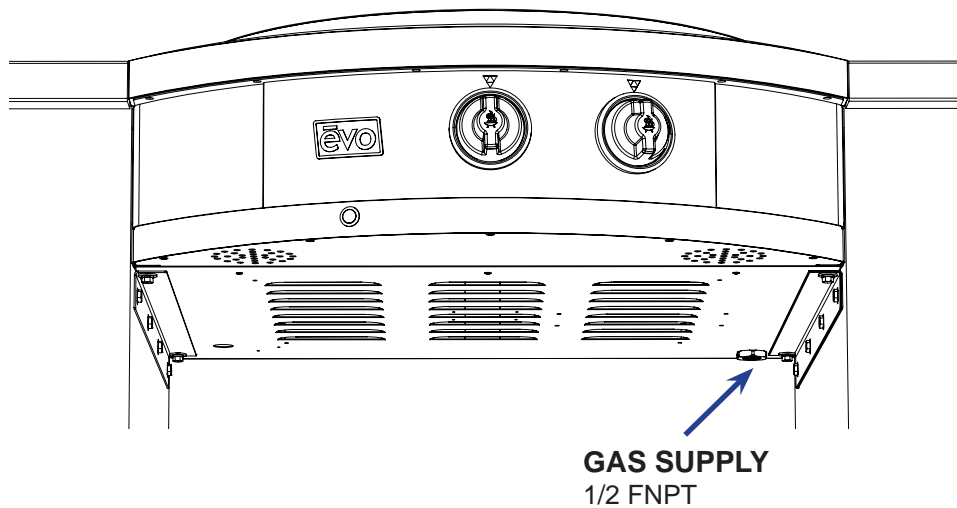

Step 11: Connect Gas using stainless steel flexible hose coupling supplied to outside gas service. All Affinity gas grills ship pre-configured for Natural Gas (NG) service unless otherwise indicated on the Safety Label mounted to the right inside spillover drawer. If configured for Natural Gas, the inlet pressure is at 7" Water Column (Fixed). If configured for LP Propane, the inlet pressure is at 11" Water Column (Fixed).

Refer to pages 21-25 for specific instructions regarding LP and NG connections, checking for gas leaks and recognizing abnormal gas operation (page 30).

CONNECTING GAS - LP CYLINDER CONNECTION



Use the pressure regulator and hose assembly supplied with your Evo cooktop. Recommended LP propane cylinder is a standard 5 gallon, 20 Lb., with a shutoff valve terminating in a cylinder valve outlet specified and an (OPD) overflow prevention device valve, compliant to current DOT specifications. If the cylinder is fitted with a Type I Cylinder Connection Device, a protective dust cap must be installed on the valve outlet.

Standard POL Regulator Install
Figure 1



Quick Disconnect Hand-Wheel Regulator Install
Figure 2

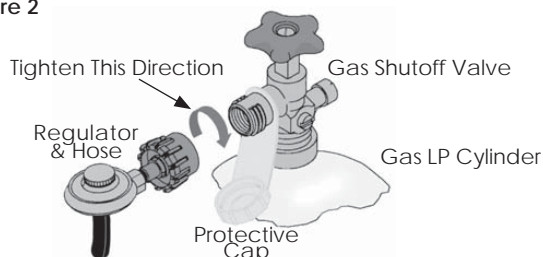

Note: Cylinder Collar removed from these illustrations for clarity

1. Be sure both cooktop burner valves are in the Off position.
2. Make sure the gas tank valve is off and in the closed position by turning clockwise (left to right) to a full stop.
3. Remove the protective cap from the gas cylinder valve.
4. Hold the supplied regulator in one hand and position the plastic coupling nut on the cylinder valve outlet threads using care to engage the center of the coupling nut to the center of the cylinder valve outlet. When completing this procedure, take care to not cross-thread the connection.
5. Observe the direction in Figure 1 and Figure 2 for installing the regulator threads to the cylinder valve. For a Standard POL Regulator turn the coupling nut counterclockwise (right to left) and tighten to a full stop. For the Quick Disconnect Regulator turn the coupling nut clockwise (left to right) and tighten to a full stop.

In the connection process, the regulator will seal on the back-check feature in the cylinder valve resulting in a slight resistance. The connection requires about a 1/2 to 3/4 additional turn to complete the connection. Tighten by hand only - do not use tools. If you cannot make the connection, disconnect the regulator and repeat steps 4 and 5.

If the unit is not in use, gas must be turned off at the supply cylinder. Inspect hoses before each use of the unit. If it is evident there is excessive abrasion or wear, or the hose is cut, it must be replaced prior to the unit being put into operation. Regulator and hose assembly can be purchased from Evo by calling 866-626-1802 or from a local gas supply company. Specifications for these parts are:

- LP Regulator: 90 degree w/ 3/8" Female SAE Inlet
- LP Hose: 60" Type #1 Low Pressure

STORAGE, REMOVAL and TRANSPORTATION OF LP CYLINDER**STORAGE & REMOVAL OF LP GAS CYLINDER:**

Never store LP gas cylinder indoors. When cooktop is stored indoors, shut cylinder valve off and disconnect cylinder from grill and remove to an outdoor location. Cylinder must be stored outdoors in well-ventilated area, away from and out of the reach of children. Cylinder should not be allowed to remain in a high heat area such as a closed car, trunk, or in direct sunlight.

Loosen coupling nut located on regulator and cylinder valve by turning counterclockwise using hands only - do not use tools. Next loosen thumb screws securing cylinder to lower rack and remove tank. Install safety cap over cylinder valve coupling.

TRANSPORTATION OF LP CYLINDER:

Never remove or alter cylinder labeling. Labels contain critical information on the safe handling of gas products. The DOT requires that proper labeling must be in place before the products can be offered for transportation.

Transporting cylinders in cars, vans, or in any enclosed vehicle is extremely dangerous, and should be avoided. Never transport flammable gases in the trunk or passenger compartment of a vehicle.

Always install the protective cap on the cylinders when they are being transported, or any time they are not in use. If the cylinders were not designed to accept a protective cap over the valve, special care must be taken to prevent the valve from damage or opening during transportation.

Secure your cylinders. The Department of Transportation (DOT) regulations require that all compressed gas cylinders be secured from movement during transportation. Cylinders that can move can open accidentally, or roll off the vehicle into the path of oncoming traffic.

Handling, storage and transportation of all gas cylinders must be in accordance with *ANSI/NFPA 58, Storage and Handling of Liquid Petroleum Gases*, or *CSA B149.1, Natural Gas and Propane Installation Code*.

 **WARNING**

Do not store spare LP gas cylinder under or near this appliance. Never fill cylinder beyond 80% full. Cylinder must be constructed and marked in accordance with the specifications for propane cylinders of the U.S. Department of Transportation (DOT), or CAN/CSA B339. If the above information is not followed exactly, a fire causing death or serious injury may occur.

PLEASE POST THESE INSTRUCTIONS IN A PROMINENT LOCATION

CHECKING GAS LEAKS (LP)

DANGER

Do not ignite burners or use an open flame to check for gas leaks. Be sure there are no sparks or open flames in the area while you check for gas leaks. Flames and sparks will result in a fire or explosion which can cause serious bodily injury or death and damage to property.

Note: All factory-made connections have been thoroughly checked for gas leaks. The burners and ignition system has been flame tested. As a safety precaution, we recommend you recheck all fittings for leaks before using your Evo grill. Shipping and handling may loosen or damage a gas fitting.

To perform a leak check you will need a solution of soap and water and a brush or rag to wet all gas connections.

1. Turn all control knobs to the OFF position.
2. Turn on gas supply and check for leaks by wetting the connections with the soap and water solution and watching for bubbles. If bubbles appear, or if a bubble grows, there is a leak.

Note: Since some leak test solutions, including soap and water, may be slightly corrosive, all connections should be rinsed with water after checking for leaks.

CHECK ALL GAS CONNECTIONS:

1. Hose to Regulator.
2. Regulator to Gas Supply connection.

WARNING

You should check for gas leaks every time you disconnect and reconnect a gas fitting.

WARNING

Perform leak checks even if your grill was dealer or store assembled.

PLEASE POST THESE INSTRUCTIONS IN A PROMINENT LOCATION

CHECKING GAS LEAKS (NATURAL GAS)

DANGER

Do not ignite burners or use an open flame to check for gas leaks. Be sure there are no sparks or open flames in the area while you check for gas leaks. Flames and sparks will result in a fire or explosion which can cause serious bodily injury or death and damage to property.

Note: All factory-made connections have been thoroughly checked for gas leaks. The burners and ignition system has been flame tested. As a safety precaution, we recommend you recheck all fittings for leaks before using your Evo cooktop. Shipping and handling may loosen or damage a gas fitting.

To perform a leak check you will need a solution of soap and water and a brush or rag to wet all gas connections.

1. Turn all control knobs to the OFF position.
2. Slide back the collar of the quick disconnect. Push the male fitting of the hose into the quick disconnect and maintain pressure while releasing the collar.
3. If fitting does not engage and lock, repeat procedure. Gas will not flow unless the quick disconnect is properly engaged.
4. Turn on gas supply and check for leaks by wetting the connections with the soap and water solution and watching for bubbles. If bubbles appear, or if a bubble grows, there is a leak.

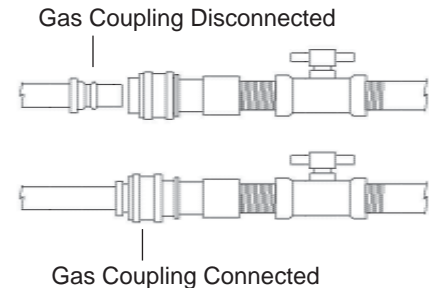

Note: Since some leak test solutions, including soap and water, may be slightly corrosive, all connections should be rinsed with water after checking for leaks.

CHECK ALL GAS CONNECTIONS:

1. Hose to Manifold Connection.

Warning: If there is a leak where the hose connects to the manifold then retighten the fitting with a wrench and recheck for leaks with soap and water. If leak continues after retightening the fitting, turn off gas. DO NOT OPERATE COOKTOP. Contact your local dealer or Evo Customer Service using the contact information provided with your manual.

2. Valves to Manifold Connections.

3. Hose to Quick Disconnect Connection.

WARNING

You should check for gas leaks every time you disconnect and reconnect a gas fitting.

WARNING

Perform leak checks even if your cooktop was dealer or store assembled.

CHECK INSTALLATION

Check to ensure the following items are complete:	PAGE #
<input type="checkbox"/> DRIP PAN PROPERLY INSTALLED Ensure that the drip pan half-rolled top bead overhangs the cutout dimension by .25" and the black o-ring is creating a seal against the countertop.	16-17
<input type="checkbox"/> DRIP PAN GASKET SECURED Black drip pan gasket should fit properly and create a seal where the drip pan meets the chassis skirt.	17
<input type="checkbox"/> COOK SURFACE INSTALLED PROPERLY Cook surface support rails should be sitting on chassis top with rear bullet secure in rear slot and two front fasteners tightened so cook surface does not move.	18-20
<input type="checkbox"/> GAS CONNECTION HOOKED UP PROPERLY Check for gas leaks. Check for proper operation.	21-25

INSTALLATION IS COMPLETE

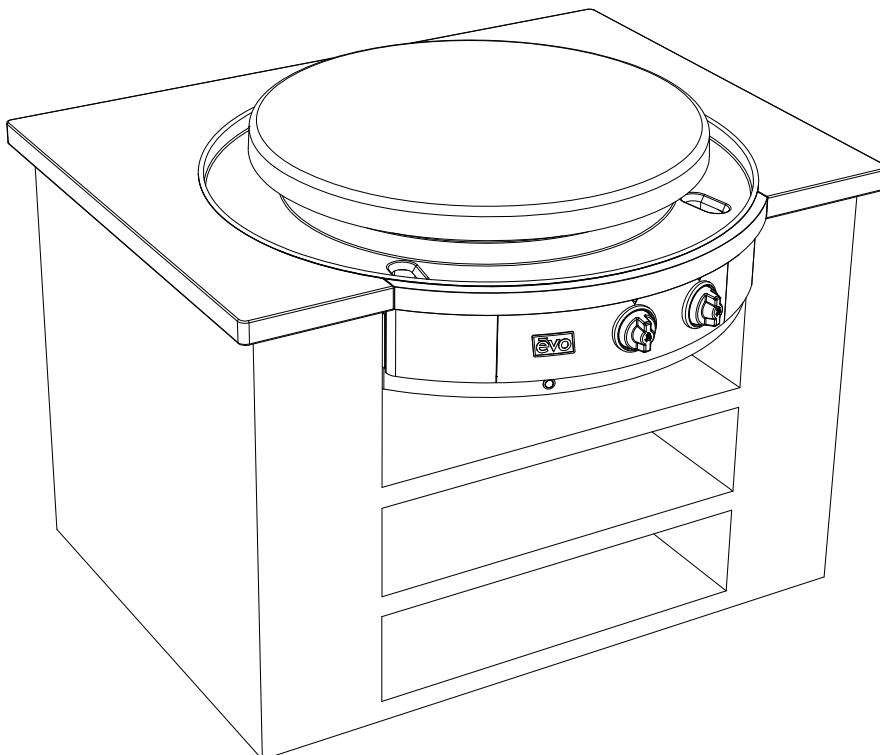

EVO AFFINITY 30G TEMPERATURE CONTROL

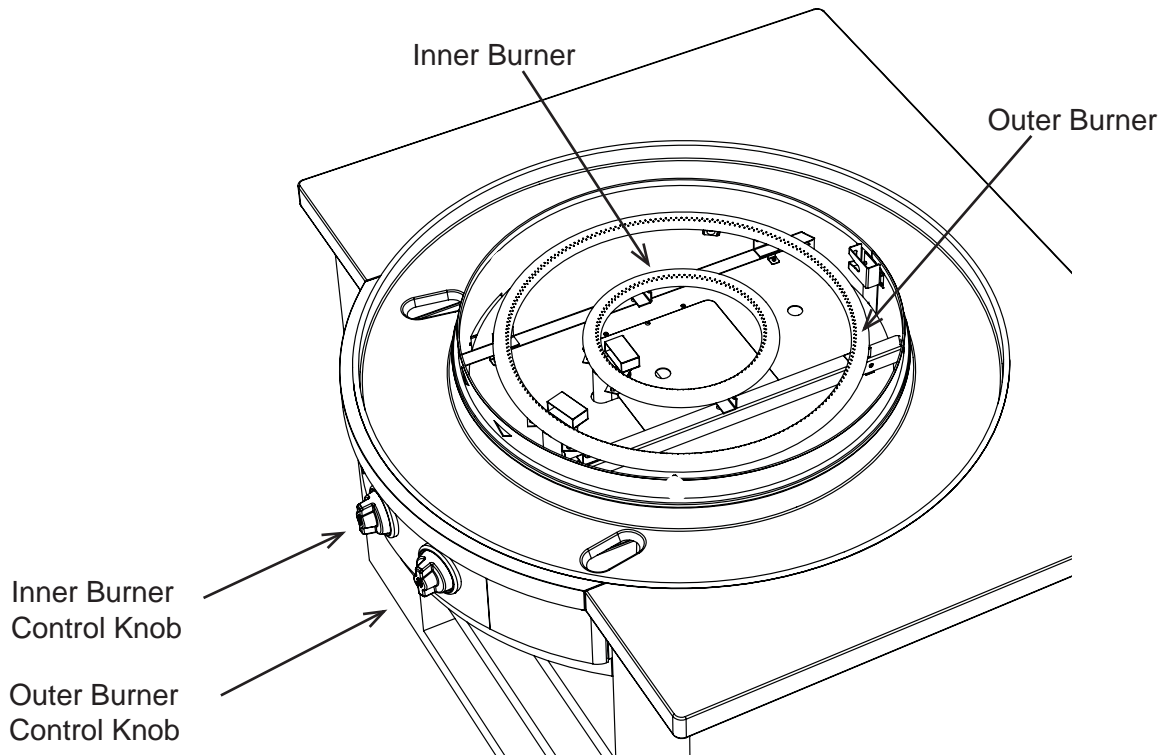

Inner Burner and Inner Control Knob - The Inner Burner is a 10" diameter gas fired burner operating at 24,000BTU's. This burner is controlled by the Inner or center-most control knob. Temperatures are adjustable from 225F° to 550F°. Starting at the Off position, the Inner Control Knob rotates 180-degrees counterclockwise through three positions.

Outer Burner and Outer Control Knob - The Outer Burner is a 20" diameter gas fired burner operating at 24,000BTU's. This burner is controlled by the Outer or outer-most control knob. Temperatures are adjustable from 225°F to 550°F. Starting at the Off position, the Outer Control Knob rotates 180-degrees counterclockwise through three positions.

Either the Inner or the Outer burners may be used independently to support a wide range of cooking techniques. Operating only the Inner burner provides direct temperature under the center of the cook surface, with indirect heat at the outside edge that is useful for holding pre and post cooking processes.

Conversely only the Outer burner can be used for cooking foods that may be displayed around the outside radius of the grill. Finally, both burners can be used together for maximum surface temperature and cooking versatility.

Because the burners are enclosed within a circular chassis and all heat is directed upward at the cook surface, cook surface temperature recovery is nearly immediate, providing a wide range of surface temperature adjustment and control.

REMOVABLE SPILLOVER TRAYS

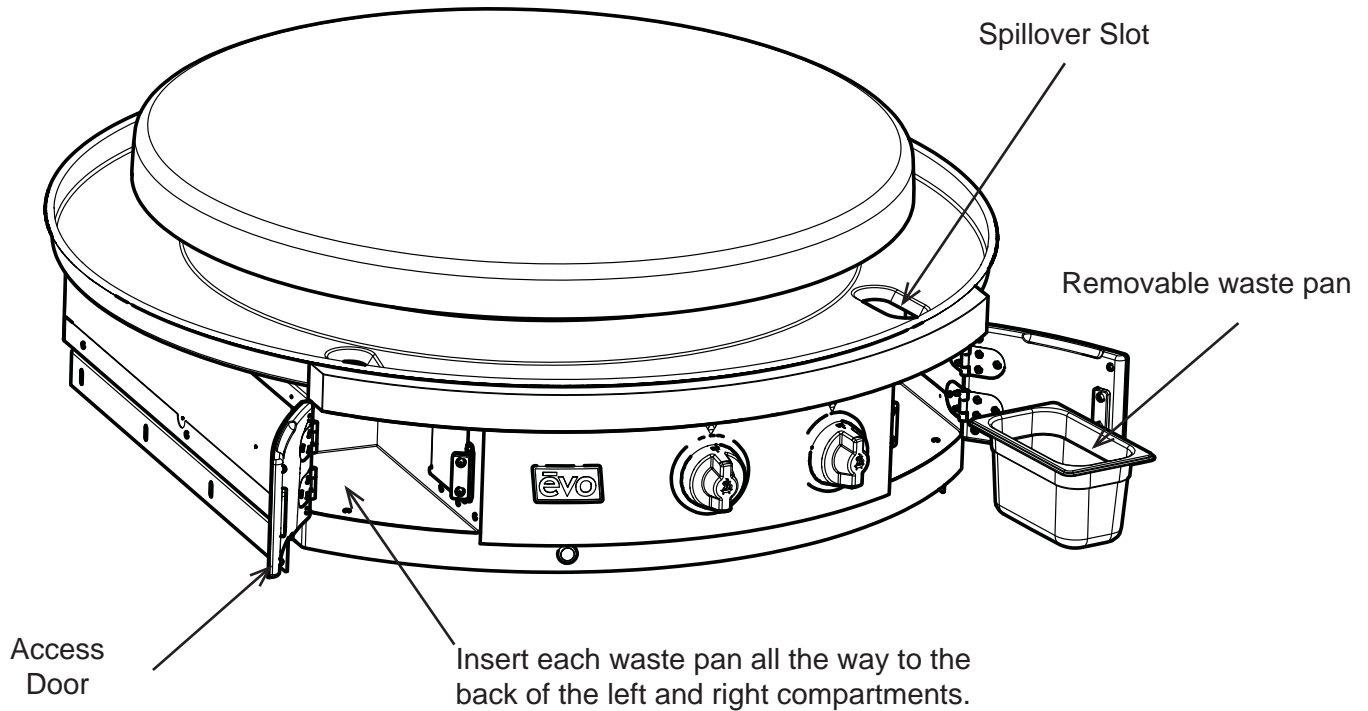

Do not operate cook top or clean drip pan into spillover slots without waste pans installed in spillover doors. Failure to install waste pan will result in cooking grease contamination to the underside of door. This requires immediate cleaning.

The Affinity grill has removable waste pans concealed in doors on both the right and left side of the front control panel. It is very important to monitor the level of spillover in the trays, and immediately empty when they are near full or after each use.

Opening Spillover Tray Doors - To open a door, grasp the door at its bottom and pull forward.



Do not allow spillover liquids or debris down spillover slots when doors are open. Any liquids or debris that may fall into this area when doors are open should be immediately wiped with a dry cloth, and keep this area clean at all times.



Do not allow the spillover trays to overflow, and do not allow full trays to splash over edge when cleaning. Spillover debris and liquids can be hot and cause burns, and/or damage to the internal operation of the grill.

LIGHTING INSTRUCTIONS



BEFORE EACH USE: Inspect gas hose under unit. If it is evident there is excessive abrasion or wear, or the hose is cut, please contact Evo for a replacement hose. See page 22 for further instructions.

Electronic Ignitor Lighting Procedure:

1. Read instructions carefully before lighting.
2. Cooking surface must be in place and secure before lighting.
3. Hold down the igniter button, then turn the Control Knob to 'Lite'. View the flame through the viewing holes in the Grill body to confirm it is lit. If the burner is lit, turn the knob to 'the desired setting to commence cooking.
4. If ignition does not occur in 5 seconds release igniter, turn the burner Control Knob off, wait 5 minutes, and repeat lighting instructions.



Control Knob

If after the repeated attempt the burner does not ignite, follow the manual lighting procedure below.

Manual Lighting Procedure:

1. To light the burner manually, feed a lit match through one of the flame viewing holes in the burner skirt above the control panel until it is close to the burner.
2. Turn the Control Knob to the 'Lite' position. View the flame through the opposite viewing hole in the grill body to confirm it is lit. If the burner is lit, turn the knob to the desired setting to commence cooking.
3. Once the burner has been lit, remove the match and extinguish the match flame.



RECOGNIZING ABNORMAL GAS OPERATION

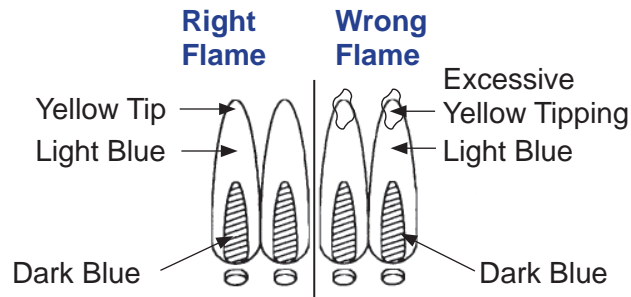

Any of the following are considered to be abnormal operation and may require servicing:

- Excessive yellow tipping of the burner flame (See diagram above).
- Sooting up of cooking utensils.
- Burners not igniting properly.
- Burners failing to remain alight.
- Gas valves, which are difficult to turn.

In case the appliance fails to operate correctly, contact the authorized service provider in your area.

Checking Venturi Tubes:

A clogged venturi tube due to insects and insect nests in the venturi tube may cause improper burner performance and difficulty lighting your grill.

To check your venturi tubes:

- Remove the cooking surface and drip pan to access the valve cover located just above the center control knob.
- Remove the cover and inspect the venturi for insects and or insect nests.
- Compressed air is the best method for removing these obstructions.



Remove cooking surface and drip pan to access valve cover located just above center control knob.

REPLACING ELECTRONIC IGNITOR BATTERY

Remove screw with #2 short handled phillips screwdriver.

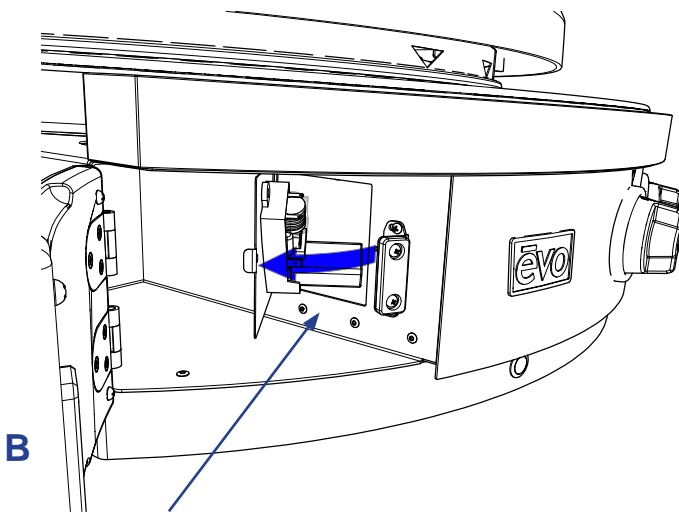
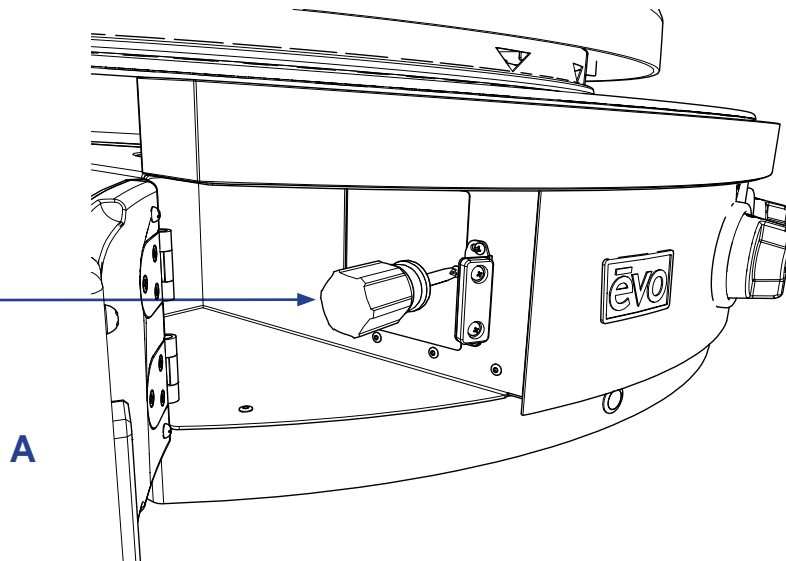

Remove the battery cover located on the inside of the left drawer opening.

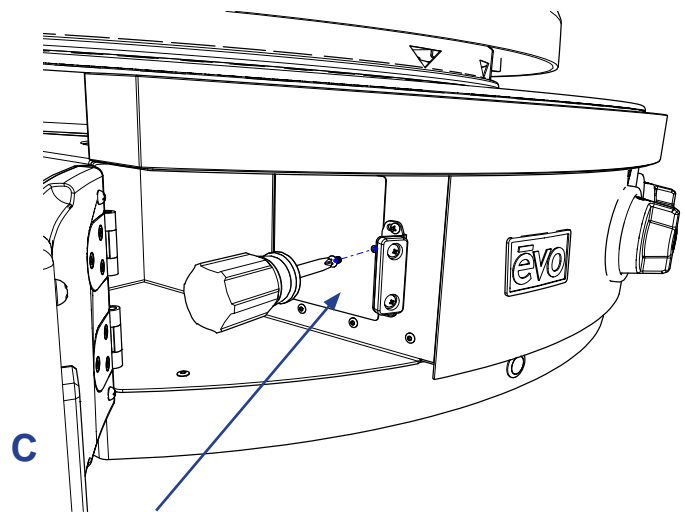

Replace screw for battery cover.

If the ignitor does not work, you may need to replace the battery.

1. Open left spillover tray door. Remove waste container.
2. Remove screw with #2 short handled phillips screwdriver. **(A)**
3. Open battery cover by sliding cover back and pulling front out. Be careful of attached ignition wires. **(B)**
4. Pull the old 9V battery out and replace with a new one. Make sure to push it in all the way. Place the cover back on. Replace screw for battery cover. **(C)**
5. If the ignitor is still not working, contact Evo Customer Support for an ignitor replacement.

AFFINITY 30G DIMENSIONS

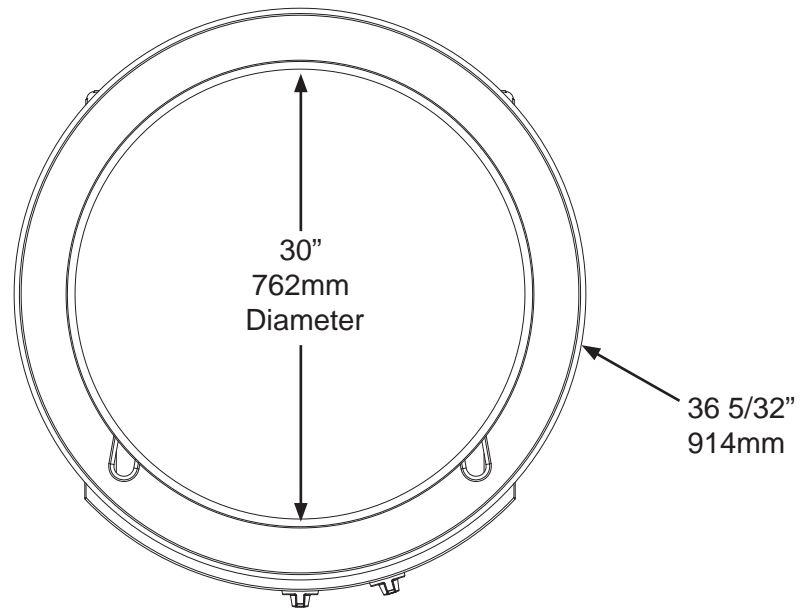

COOK SURFACE MAINTENANCE

Regular cleaning and care for your Evo Affinity 30G cooktop will keep it looking and functioning its best.

The cook surface is designed to hold a fine layer of cooking oil creating a 'seasoning' on its surface. This seasoning promotes a non-stick cooking surface and is easily maintained.

Caring for Evo's cook surface is much like maintaining cast iron cookware. When the surface requires cleaning, there are a few basic cleaning techniques to use. For quick and routine cleaning between preparations, a metal spatula or scraper works for removing the majority of surface debris. For tougher areas or where sugars glaze the cook surface, pour a small amount of warm water on the soiled surface while the grill is warm and scrape the debris away with a spatula. Heat the cook surface to a high temperature and allow the sticky debris to become brittle. Once the debris is brittle, use the spatula or scraper to remove it. Afterwards wipe the cook surface with vegetable oil again before cooking.

To condition the Evo cook surface you should use the grill cleaning kit supplied with your grill. The grill cleaning kit contains a blue grill pad handle, grill cleaning screens, and grill grey polishing pads. Use the polishing pad after the grill cleaning pads to achieve a smooth cooking surface for the most delicate foods and applications.

To use a grill cleaning screen: With a warm cook surface, place one gray polishing pad between the grill handle base and the grill screen, so the grill screen makes direct contact with the cooking surface. Pour a small amount of vegetable oil on the cook surface and scrub the surface in a circular motion. The gray polishing pad allows excess oil to be absorbed and scours the cooking surface of carbonized debris. When finished scrubbing, wipe the surface down with a paper towel or cotton terry cloth.

The drip pan located just below the cook surface is designed to catch food debris and drippings from the cook surface. We recommend cleaning the drip pan after your grill has cooled to prevent the possibility of touching hot adjoining surfaces. The drip pan is easy to wipe out with soap and water using a kitchen sponge. For added convenience, two removable stainless ninth-pans are mounted inside retractable drawers at right and left side of the front control panel for collecting drip pan debris and spill overs. These spillover trays can be easily washed by hand or in a dishwasher. Be sure to empty the spillover trays after every use, and at a minimum, whenever they appear half full.

All the stainless steel components on your grill can be easily polished using a stainless steel cleaner/polish. Stainless steel cleaner can be purchased from the Evo web site along with replacement grill cleaning and polishing pads. The Evo web site address is: www.evoamerica.com.

Thank You For Cooking With Evo!